

# MULTI-LOAD DRYERS

ENERGY ADVANTAGE LINE – VEND: MDG35, MDG52, AND MDG78



## MICROPROCESSOR CONTROLS

- Easy-to-read diagnostics assist with quick identification of an issue helping to get the machine back into service
- Owners can control time-of-day pricing and additional costs for end-user upgrades
- End users have option to select ideal cycle for individual drying needs
- Easy-to-read Time Remaining Digital Display informs users of cycle times to help reduce bottlenecks



## AXIAL AIRFLOW SYSTEM

- Consistent drying with low BTUs
- Helps manage utility costs while still providing effective drying for efficient machine turnover



## OWNER-PROGRAMMABLE SINGLE-PHASE REVERSING CYLINDER

- Helps separate fabrics to promote effective dry cycles helping to reduce tangling and wrinkles



## BUILT TO LAST

- Four Roller Suspension with Permanently Lubricated Bearings - provides consistent drying
- Heavy Duty Motor – designed to handle large loads with ease
- Extra-Large Door Opening with Dual-Pane Door Glass – provides unhindered access while loading and unloading, and dual-pane glass helps keep heat inside for optimal drying



COIN EQUIPPED  
MDG78PDBWS pictured  
(Also available in white)

MULTI-LOAD DRYERS – ENERGY ADVANTAGE LINE		
CAPACITY	MODEL NUMBER	COLOR
35 lb	MDG35PDBWW	White
35 lb	MDG35PDBWS	Stainless
50 lb	MDG52PDBWW	White
50 lb	MDG52PDBWS	Stainless
75 lb	MDG78PDBWW	White
75 lb	MDG78PDBWS	Stainless



**AMERICA**  
AN AMERICAN COMPANY FOR OVER 100 YEARS

See [maytagcommerciallaundry.com](http://maytagcommerciallaundry.com) for warranty details.

VISIT [MAYTAGCOMMERCIALLAUNDRY.COM](http://MAYTAGCOMMERCIALLAUNDRY.COM) FOR MORE INFORMATION.

# MULTI-LOAD DRYERS

## ENERGY ADVANTAGE LINE – VEND: MDG35, MDG52, AND MDG78



### GAS MULTI-LOAD DRYERS 120V/60 HZ/1 PHASE

#### MDG78

FRONT VIEW

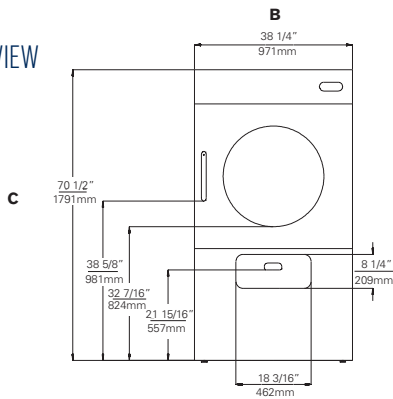

SIDE VIEW

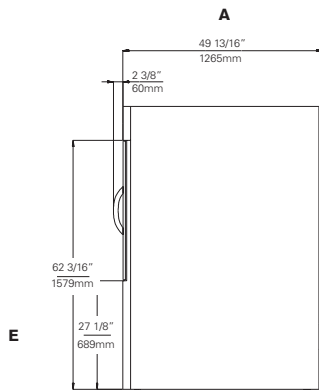

REAR VIEW

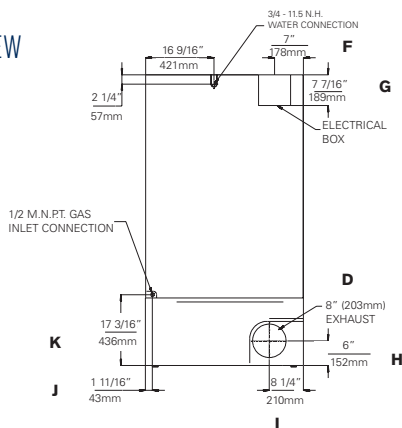

Dimensions are for planning purposes only. See specific instructions for proper installation. Because of continuous product improvement, Maytag reserves the right to change specifications without notice.

MODEL	MDG35 (PD)	MDG52 (PD)	MDG78 (PD)
<b>CAPACITY</b>			
Number of Dryer Pockets	1	1	1
Cylinder Volume Each Pocket — cu. ft. (liters)	12.27 (347.45)	16.02 (453.64)	22.09 (625)
Cylinder Diameter Each Pocket — in. (mm)	30 (762)	37 (940)	37 (940)
Cylinder Depth Each Pocket — in. (mm)	30 (762)	25.75 (654)	35.51 (902)
Dry Load Capacity Each Pocket — lb (kg)	35 (15.88)	50 (22.68)	75 (34.02)
<b>GAS SPECS/AIRFLOW</b>			
Drive Motor Size — hp (kW)	¼ (.19)	¾ (.56)	¾ (.56)
Blower Motor Size — hp (kW)	½ (.37)	½ (.37)	½ (.37)
Airflow Type	Axial	Axial	Axial
Airflow — cfm (cmm)	319 (90.30)	600 (17)	600 (17)
Gas Inlet Size — in. (mm)	.5 (12.70) M.N.P.T.	.5 (12.70) M.N.P.T.	.5 (12.70) M.N.P.T.
Heat Input, Gas — btu/hr (kcal/hr)	64,000 (16,128)	110,000 (27,720)	130,000 (32,760)
Number of Exhausts	1	1	1
(D) Exhaust Duct Diameter — in. (mm)	6 (152)	8 (203.2)	8 (203.2)
<b>ELECTRICAL REQUIREMENTS</b>			
Breaker/Fuse — amps	15	20	20
<b>DIMENSIONS</b>			
(A) Depth — in. (mm)	40.43 (1,027)	40.13 (1,019)	49.81 (1,265)
(B) Width — in. (mm)	31.13 (791)	38.25 (972)	38.25 (972)
(C) Height — in. (mm)	67 (1,702)	70.50 (1,791)	70.50 (1,791)
Door Opening — in. (mm)	19.38 (492)	27.36 (695)	27.36 (695)
(E) Height to Bottom of Door — in. (mm)	32-11/16 (830)	27-1/16 (687)	27-1/8 (689)
(F) Width to Center of Electrical Box — in. (mm)	5-15/32 (139)	7 (178)	7 (178)
(G) Height of Electrical Box — in. (mm)	7-5/16 (185)	7-7/16 (189)	7-7/16 (189)
(H) Height to Center of Exhaust — in. (mm)	20-13/32 (523)	6 (152)	6 (152)
(I) Width to Center of Exhaust — in. (mm)	11-19/32 (294)	8-1/4 (210)	8-1/4 (210)
(J) Width to Center of Gas Inlet — in. (mm)	4-3/8 (111)	1-11/16 (43)	1-11/16 (43)
(K) Height to Center of Gas Inlet — in. (mm)	25-13/16 (655)	17-3/16 (436)	17-3/16 (436)
<b>APPROXIMATE WEIGHT</b>			
Uncrated — lb (kg)	462 (209)	610 (277)	745 (338)
Crated — lb (kg)	492 (223)	640 (290)	775 (352)
<b>CONTROL/USER INTERFACE</b>			
Control Type	Microprocessor	Microprocessor	Microprocessor
Display Type	Digital	Digital	Digital
Vended Controller	Microprocessor	Microprocessor	Microprocessor
Card Reader Ready	Yes	Yes	Yes
OPL Controller	No	No	No
<b>CONSTRUCTION</b>			
Cylinder	Galvanized Steel	Galvanized Steel	Galvanized Steel
Top	Painted CRS	Painted CRS	Painted CRS
Front	White/Stainless Steel	White/Stainless Steel	White/Stainless Steel
Side	Painted CRS	Painted CRS	Painted CRS